

PZ221E User Manual

E-618 High-Power Piezo Amplifier / Controller

Release: 1.0.0 Date: 23 June 2010



This document describes the following product(s):

- E-618.10
High-Power Piezo Amplifier Module, 1 Channel,
-30 to 130 V, 20 A
- E-618.10G
High-Power Piezo Amplifier, 1 Channel,
-30 to 130 V, 20 A, 9.5" Chassis
- E-618.1G
High-Power Piezo Controller, 1 Channel, -30 to 130 V,
20 A, Controller & Interface/Display Upgrade possible,
19" Chassis
- E-618.20G
High-Power Piezo Amplifier, 2 Channels, -30 to 130 V,
20 A, 19" Chassis

Physik Instrumente (PI) GmbH & Co. KG is the owner of the following company names and trademarks: PI®, PIC®, PICMA®, PILine®, PIFOC®, PiezoWalk®, NEXACT®, NEXLINE®, NanoCube®, NanoAutomation®

The following designations are protected company names or registered trademarks of third parties: LabVIEW

The products described in this document are in part protected by the following patents:
US Patent No. 6,950,050

Copyright 2010 by Physik Instrumente (PI) GmbH & Co. KG, Karlsruhe, Germany.
The text, photographs and drawings in this manual enjoy copyright protection. With regard thereto, Physik Instrumente (PI) GmbH & Co. KG reserves all rights. Use of said text, photographs and drawings is permitted only in part and only upon citation of the source.

First printing 23 June 2010
Document Number PZ221E BRo, Release 1.0.0
E-618_User_PZ221E100.doc

Subject to change without notice. This manual is superseded by any new release. The newest release is available for download at www.pi.ws (<http://www.pi.ws>).

About this Document

Users of this Manual

This manual is designed to help the reader to install and operate the E-618 High-Power Piezo Amplifier/Controller. It assumes that the reader has a fundamental understanding of motion control concepts and applicable safety procedures.

The manual describes the physical specifications and dimensions of the E-618 High-Power Piezo Amplifier/Controller as well as the procedures which are required to put the system into operation.

Conventions

The notes and symbols used in this manual have the following meanings:

WARNING

Calls attention to a procedure, practice or condition which, if not correctly performed or adhered to, could result in injury or death.



DANGER

Indicates the presence of high voltage (> 50 V). Calls attention to a procedure, practice or condition which, if not correctly performed or adhered to, could result in injury or death.



CAUTION

Calls attention to a procedure, practice, or condition which, if not correctly performed or adhered to, could result in damage to equipment.



NOTE

Provides additional information or application hints.

The optional components which might be mentioned in this document are described in their own manuals. All documents are available as PDF files. Updated releases are available for download at www.pi.ws (<http://www.pi.ws>) or via e-mail: contact your Physik Instrumente Sales Engineer or write info@pi.ws (<mailto:info@pi.ws>).

Related Documents

E-509_User_PZ77E
E-517_User_PZ214E
E-515_User_PZ68E

Contents

1	Introduction	3
1.1	Overview	3
1.2	Prescribed Use.....	4
1.3	Safety Precautions	5
1.4	Model Survey and Upgrades.....	7
1.5	Additional Components	8
1.6	Unpacking	9
2	Operation	10
2.1	Calibrated System.....	10
2.2	Installation	10
2.3	15-Pin Main Connector on E-618.10 Modules	12
2.4	Front Panel Elements.....	13
2.5	Line Voltage Connection	14
2.6	Piezo Actuator Connection.....	15
2.7	Temperature Sensor Connection	16
2.8	Control Signal Connection	17
2.8.1	Analog Operation.....	17
2.8.2	Remote Control via Computer Interface.....	17
2.9	Modes of Operation.....	18
2.9.1	Open-Loop Operation.....	18
2.9.2	Closed-Loop Operation	18
2.10	First Steps	18
2.11	Zero-Point Adjustment in Closed-Loop Operation with E-509	20
2.12	Protection Against Overheating	21
3	Maintenance	22
3.1	AC Power and Line Power Fuses	22
3.2	Cleaning	23
4	Troubleshooting	24
4.1	Mechanics Does not Move	24
4.2	The TEMP OFL LED Lights	24
4.3	Customer Service.....	24
5	Technical Data	25

5.1	Specifications	25
5.2	Frequency Response Diagram	26
5.3	Block Diagram	27
5.4	Signal Path with Servo-Controller and PC-Interface Modules	28
6	Appendix	29
6.1	Lifetime of PICMA® Actuators	29
6.2	Power Bandwidth	31

1 Introduction

1.1 Overview

The E-618.10 high-power amplifier module is specifically designed for ultra-high-dynamics operation of piezo actuators. It can output and sink a peak current of 20 A and an average current of 800 mA in a voltage range of -30 to 130 V. Besides the amplifier module, three standard configurations are available:

- E-618.10G is a bench-top amplifier in a 9.5" chassis, for open-loop operation (1 channel)
- E-618.1G is the amplifier module in a 19" rackmount chassis that can hold additional E-509 controller and E-517 interface / display modules
- E-618.20G is a 2-channel version in a 19" rackmount chassis

Fast Switching

The amplifier features a high bandwidth of more than 15 kHz combined with extremely short rise times in the microsecond range and a high output power. This makes it ideal for fast switching applications for valves, pumps, for microstructure and material testing. Furthermore, it is perfectly suited for systems for active vibration control.

Piezo Overtemperature Protection

To protect the mechanics especially in high-dynamics applications, the E-618 features a temperature sensor input and controller circuit that shuts down the amplifier if the piezo actuator exceeds the maximum temperature threshold.

Analog and Digital Control

All E-618 amplifiers come with a high bandwidth analog interface. An optional 24-bit computer interface for integration in E-618.1G models is available as E-517.

Ceramic-Insulated Piezo Actuators Provide Superior Lifetime

The highest possible reliability is assured by employing PICMA® multilayer piezo actuators. PICMA® actuators have a ceramic-only insulation which makes them resistant to ambient humidity and leakage-current failures. They are thus far superior to conventional actuators in reliability and lifetime.

Note: Spezial Connector Required

The high electrical currents require adequate connectors and cabling. Therefore, standard piezo systems and actuators have to be adapted.

1.2 Prescribed Use

Based on their design and realization, E-618 High-Power Piezo Amplifiers are intended to drive capacitive loads, in the present case, piezoceramic actuators with high-current termination electrodes. E-618s must not be used for applications other than stated in this manual, especially not for driving ohmic (resistive) or inductive loads.

Observe the safety precautions given in this User Manual.

The E-618 may only be used for applications suitable according to the device specifications. Operation other than instructed in this User Manual may affect the safeguards provided.

The verification of the technical specifications by the manufacturer does not imply the validation of complete applications. In fact the operator is responsible for the process validation and the appropriate releases.

The E-618 is a laboratory apparatus as defined by DIN EN 61010. It meets the following minimum specifications for safe operation:

- Indoor use only
- Altitude up to 2000 m
- Temperature range 5°C to 40°C
- Max. relative humidity 80% for temperatures up to 31°C, decreasing linearly to 50% relative humidity at 40°C
- Line voltage fluctuations not greater than $\pm 10\%$ of the line voltage
- Transient overvoltages as typical for public power supply
Note: The nominal level of the transient overvoltage is the standing surge voltage according to the overvoltage category II (IEC 60364-4-443).
- Degree of pollution: 2

These data are no limitations for the specifications in the technical data table (p. 25).

1.3 Safety Precautions

Install and operate the E-618 High-Power Piezo Amplifier only when you have read the operating instruction.

Keep the instruction readily available close to the device in a safe place.

When the instruction is lost or has become unusable, ask the manufacturer for a new copy.

Add all information given by the manufacturer to the instruction, e.g. supplements or Technical Notes.



WARNING

The E-618 amplifier is capable of generating high output voltages and high output currents. It may cause serious or even lethal injury if used improperly.

Working with high-voltage amplifiers requires adequately trained operating personnel. Strictly observe the following:

- Do not touch the pins of the LEMO connector which carries the piezo output voltage. The high voltage output may be active whenever the device is turned on. The output value depends on the control input. Voltages between -30 V and +130 V can be present on the LEMO connector.
- The E-618 amplifier does not contain any user-serviceable parts. Never disassemble the device. Hazardous voltage can be present on the internal components.



DANGER

All work done with and on the E-618.10 amplifier module requires adequate knowledge and training in handling high voltages and high currents.

Allow operation of the E-618.10 amplifier module only if installed properly:

- Install E-618.10 in a shielded, EMC-compatible enclosure.
- Provide suitable line filter and fuses for the line voltage connection and install them in the enclosure.

- Connect pin 32 of the 15-pin main connector on the rear of the E-618.10 amplifier module to a protective earth conductor.

WARNING

Connect the AC power cord of the E-618 to the wall socket (220 VAC to 240 VAC or 100 VAC to 120 VAC). New line-power fuses are required when changing the supply voltage. Both fuses are active and have to be replaced or checked if there is a fault. See "AC Power and Line Fuses" (p. 22) for how to replace the line power fuses.

Connect an E-618.10 amplifier module to the wall socket only if installed properly.

To disconnect the system from the supply voltage completely, remove the power plug from the wall socket.

Install the system near the AC outlet and such that the AC power plug can be reached easily.



CAUTION

Do not cover the ventilation slots on the top side of the E-618. Place the system in a location with adequate ventilation to prevent internal heat build-up. The device needs to be installed horizontally with 3 cm air circulation area. Vertical mounting prevents internal convection. Insufficient air flow will cause overheating and premature failure.

When installing the E-618.10 amplifier module, make sure that the enclosure is equipped with suitable ventilation slots for free air circulation and internal convection.



CAUTION

Use only PICMA® piezo actuators with high-current termination electrodes. Standard piezo systems and actuators have to be adapted before they can be used with the E-618. Contact your PI sales engineer or write info@pi.ws.

For dynamic applications, or continuous operation, the use of a temperature sensor (PT1000) on the piezo actuator is recommended, to avoid destruction of the piezo due to heat generation. See p. 16 for details.



1.4 Model Survey and Upgrades

The E-618 series of amplifiers/controllers is based on the following module:

E-618.10 High-Power Piezo Amplifier Module, 1 Channel,
-30 to 130 V, 20 A

The E-618.10 module can be ordered separately and is furthermore available integrated in the following standard configurations:

E-618.10G High-Power Piezo Amplifier, 1 Channel,
-30 to 130 V, 20 A, 9.5" Chassis

E-618.1G High-Power Piezo Controller, 1 Channel, -30 to 130 V,
20 A, 19" Chassis.
Upgradable with a servo-control module (E-509), and/or a computer interface and display module (E-517, E-515 for display only). All modules ordered come installed directly in the 19" chassis. If the servo module and a piezo actuator are ordered with the system, your E-618.1G will be fully calibrated before being shipped.

E-618.20G High-Power Piezo Amplifier, 2 Channels, -30 to 130 V,
20 A, 19" Chassis

Contact your PI sales engineer or write info@pi.ws, if you want to upgrade your E-618.1G. Any additional modules are described in their own separate manuals.

The following modules are available:

E-509.C1A,
E-509.L1,
E-509.S1 Sensor / Servo-Controller Module for capacitive, LVDT or SGS position sensors respectively, 1 channel to eliminate drift and hysteresis from positioning operations.

E-517.i1 Interface / Display Module, 24 bit D/A, TCP/IP, USB, RS-232, IEEE 488, Single Channel; displays the current voltage and, if servo-module also present, the position of the PZT, communicates with a host PC for remote control of the E-618. DLL, LabVIEW drivers and convenient interactive user interface software are provided.

E-515.01 Display Module for PZT Voltage and Position, 1 channel

1.5 Additional Components

Contact your PI sales engineer or write info@pi.ws, if you need one of the additional components listed below.

Extension cables for the piezo stages:

E-618.X11	Piezo cable, 1 m, Lemo 2-pin/open end for soldering piezo actuators
E-618.X01	Extension cable, Lemo 2-pin m/f, 1 m
E-618.X03	Extension cable, Lemo 2-pin m/f, 3 m

The E-618 can be controlled via a signal connected to its analog input line (see "Analog Operation", p. 17, for more information). This signal can, for example, be generated using a D/A board in a PC. PI offers a LabVIEW driver set which can be used with certain D/A boards. It is compatible with the PI General Command Set (GCS) LabVIEW driver set available for all newer controllers from PI. For order numbers see below:

E-500.ACD	CD with LabVIEW analog driver set, available free of charge upon request. The PI LabVIEW drivers support all D/A converter boards from National Instruments that are compatible with DAQmx8.3. LabVIEW compatibility is given from version 7.1 upwards.
E-500.HCD	Access to HyperBit Functionality for Enhanced System Resolution (Supports Certain D/A Boards). PI's patented HyperBit technology for providing position resolution higher than that of the D/A board is included in the E-500.ACD driver set. Activating HyperBit requires purchase of the password, which can be obtained from PI under Order No. E-500.HCD.

1.6 Unpacking

Unpack the E-618 with care. Compare the contents against the items covered by the contract and against the packing list.

The following components are included with all E-618 models:

PZ221E	User manual for E-618 (this document)
000016103	Dummy plug for the temperature sensor socket, must be used when the piezo actuator connected to the E-618 does not feature a temperature sensor
E500T0011	Technical Note for LabVIEW Analog Driver Set

E-618.10 amplifier modules in addition come with:

824005964	Backplane connector type H, 15-pole, female contacts, with straight 4.0-mm solder pins, type Harting 0906.. (F127.200); matches the 15-pin main connector of E-618; for installation completely inside the user housing
-----------	---

E-618.10G, .1G and .20G models in addition come with:

3763	Line cord
------	-----------

Inspect the contents for signs of damage. If parts are missing or you notice signs of damage, contact PI immediately.

Save all packing materials in case the product needs be shipped again.

2 Operation

2.1 Calibrated System

If an E-618.1G with an included servo module is ordered together with a piezo actuator, the system will be fully calibrated at PI according to your specifications before being shipped, and will come with a calibration information sheet.

Calibration should only be done by qualified authorized personnel after consultation with PI, otherwise internal configuration data may be destroyed by erroneous operation.

If you inform PI about your application, your E-618.1G will be fully calibrated before being shipped. It is usually not necessary for you to do anything more than adjust the zero point before operating the system.

Do not interchange controller (whole devices or individual modules) and/or piezo stages if they are matched and calibrated together. Respect the assignment of the piezo actuators to the individual controller channels, as indicated by the serial numbers on the labels affixed to the devices. With multi-axis stages respect the channel/axis assignments indicated by the cable labeling

2.2 Installation

DANGER

All work done with and on the E-618.10 amplifier module requires adequate knowledge and training in handling high voltages and high currents.

Allow operation of the E-618.10 amplifier module only if installed properly:

- Install E-618.10 in a shielded, EMC-compatible enclosure.
- Provide suitable line filter and fuses for the line voltage connection and install them in the enclosure.
- Connect pin 32 of the 15-pin main connector on the rear of the E-618.10 amplifier module to a protective earth conductor.





CAUTION

Do not cover the ventilation slots on the top side of the E-618. Place the system in a location with adequate ventilation to prevent internal heat build-up. The device needs to be installed horizontally with 3 cm air circulation area. Vertical mounting prevents internal convection. Insufficient air flow will cause overheating and premature failure.

When installing the E-618.10 amplifier module, make sure that the enclosure is equipped with suitable ventilation slots for free air circulation and internal convection.

For installing an E-618.10 amplifier module proceed as follows:

- 1 Provide a suitable enclosure with connections for the signals on the rear 15-pin main connector of the E-618 module. See section 2.3 for pinout of the 15-pin main connector and section 2.5 for line voltage connection details.

For connection inside the enclosure, you can use the included backplane connector or other suitable female multipoint connectors. See the note below for details and recommendations.

- 2 Insert the module into the enclosure. Make sure that its 15-pin main connector is fitted in the backplane connector.
- 3 Fix the module to the enclosure using the four included cross-head screws on the front panel corners.

NOTE

Details regarding the included backplane connector (PI order No. 824005964): type H, 15-pole, female contacts, with straight 4.0-mm solder pins, Harting 0906.. (F127.200)

Other recommended female connectors according to EN 60603 (DIN 41612) H 15F:

Manufacturer: Schroff, order numbers (Schroff):

69001-981 solder pins, length 4 mm, 0.8 mm x 0.8 mm; straight

69001-980 solder pins, length 10 mm, 0.8 mm x 0.8 mm; straight

69001-733 FASTON connector 6.3 mm x 0.8 mm; straight

2.3 15-Pin Main Connector on E-618.10 Modules

Connector type: 15-pin male connector type H with protective earthing contact (z32), according to EN 60 603 (DIN 41 612)

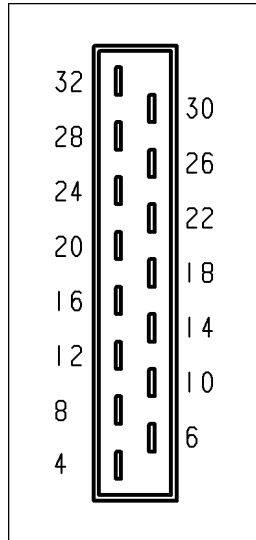

Pin	Function
4	GND (power)
6	+15 V, 0.3 A (e.g. for a display electronics)
8	-15 V, 0.3 A (e.g. for a display electronics)
10	+5 V, 1.0 A (e.g. for a display electronics)
12	GND (measurement)
14	Control output (CONTROL INPUT + DC-OFFSET)
16	Monitor of piezo output voltage (1% of "PZT" output)
18	Control input to amplifier stage
20	Sync (-) (return conductor)
22	Sync (+) input (TTL, 200 Hz, 50% duty cycle recommended)
24	Line voltage, neutral conductor
26	n.c.
28	Line voltage, if set for 100 to 120 VAC
30	Line voltage, if set for 220 to 240 VAC
32	Protective earth

NOTES

The line voltage connection is to be done as follows:
 220 VAC to 240 VAC: Use pins 24, 30 and 32.
 100 VAC to 120 VAC: Use pins 24, 28 and 32.
 Never connect both pins 28 and 30 at the same time!

Pins 14 and 18 must be interconnected.

Pins 20 and 22 can be used to synchronize the E-618.10 using an external TTL signal.

If you use an E-517 interface and display module, you have to connect it to E-618.10 via pins 4, 6, 8, 10, 12, 14, 16, 18, 20 and 22.

If you use an E-509 servo-control module, you have to connect it to E-618.10 via pins 4, 6, 8, 12, 14 and 18. Pins 20 and 22 only have to be connected with E-509 models for capacitive sensors.

2.4 Front Panel Elements



Name	Function
DC-OFFSET	10-turn potentiometer for DC offset
POWER LED (green)	Green light indicates that the device is powered on.
TEMP OFL LED (red)	Red light indicates that the temperature on the connected temperature sensor exceeds 150 °C. The output voltage for the piezo actuator is then deactivated (p. 16).
TEMP SENSOR	Lemo socket for connection of a PT1000 temperature sensor (p. 16). When the piezo actuator connected to the E-618 does not feature a temperature sensor, the included dummy plug must be used.
CONTROL INPUT	BNC connector for control input voltage. -2 to 12 V is the recommended control input range, resulting in -20 to 120 V piezo output voltage (without DC-offset potentiometer usage). -3 to 13 V control input are possible and will result in -30 to 130 V output voltage (without DC-offset potentiometer usage), but working with increased output voltage will decrease actuator lifetime. See "Lifetime of PICMA® Actuators" on p. 29 for details.
PZT	Lemo socket for piezo stage, carries the output voltage for the piezo actuator (-30 to 130 V) in the stage; with security cover

E-618.1G models may be equipped with optional servo-control (E-509) and PC interface/display (E-517, E-515) modules. The controls of these modules are described in their own separate manuals.

2.5 Line Voltage Connection

Models with Chassis:

Unless you request otherwise, upon delivery the E-618 will be set up for the voltage predominant in your country, either

110 V ~ / 50-60 Hz

or

230 V ~ / 50-60 Hz

To adapt the E-618 to a different line voltage, the line power fuses must be replaced. See “AC Power and Line Power Fuses” (p. 22) for instructions and for the required fuse types.

Connect the included line cord from the E-618 rear panel to an appropriate power outlet.

E-618.10 Amplifier Modules:

DANGER

All work done with and on the E-618.10 amplifier module requires adequate knowledge and training in handling high voltages and high currents.

Connect an E-618.10 amplifier module to the wall socket only if installed properly:

- Install E-618.10 in a shielded, EMC-compatible enclosure.
- Provide suitable line filter and fuses for the line voltage connection and install them in the enclosure.
- Connect pin 32 of the 15-pin main connector on the rear of the E-618.10 amplifier module to a protective earth conductor.



The line voltage connection is to be done via the following pins of the 15-pin main connector (pinout on p. 12):

220 VAC to 240 VAC: Use pins 24, 30 and 32.

100 VAC to 120 VAC: Use pins 24, 28 and 32.

Never connect both pins 28 and 30 at the same time!

We recommend the following line filter:

PE0SXDS6B, Corcom

For the fuses to be used with the line filter see p. 22 for an orientation.

Depending on the design of your system, it may be necessary to use other line filters and fuses.

2.6 Piezo Actuator Connection



CAUTION

Use only PICMA® piezo actuators with high-current termination electrodes. Standard piezo systems and actuators have to be adapted before they can be used with the E-618. Contact your PI sales engineer or write info@pi.ws.

For dynamic applications or continuous operation, the use of a temperature sensor (PT1000) on the piezo actuator is recommended, to avoid destruction of the piezo due to heat generation. See p. 15 for details.

Connect the piezo system or actuator to the E-618 via the “PZT” Lemo socket on the front panel.



DANGER

E-618 amplifiers output high voltages and high currents which can cause death or injury!

Take special care if connecting products from other manufacturers. Follow general accident prevention rules!

Modifications of high voltage connectors must be carried out by adequately trained and educated personnel.

If your PICMA® piezo actuator with high-current termination electrodes is not equipped with a connector, you have to attach a suitable connector according to the type and pinout of the “PZT” socket shown below. A connecting cable with open end for soldering piezo actuators can be ordered separately, order No. E-618.X11.

“PZT” socket on E-618:

Type: LEMO
EGG.1B.302.CLL with 2 conductors and a shield

Pin Assignments:

PZT Out: Piezo output, -30 to 130 V
PGND: Power ground
Housing: Cable shield, for protective ground

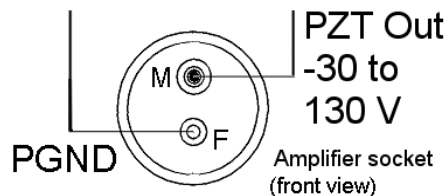

2.7 Temperature Sensor Connection

E-618 amplifier modules are equipped with a temperature monitoring circuit to avoid overheating of the connected mechanics. It can be used with PT1000 temperature sensors.

Connect the PT1000 to the “TEMP SENSOR” Lemo socket on the front panel of the E-618. When the mechanics connected to the E-618 does not feature a temperature sensor, the included dummy plug (order No. 000016103) must be used.

When a temperature of 150 °C is detected on the mechanics, the E-618 temperature monitoring circuit deactivates the output of the amplifier (“PZT” socket), and the red “TEMP OFL” LED on the front panel lights up. See p. 21 for how to proceed in this case.

To avoid overheating, you can reduce the maximum operating frequency and output voltage. The maximum operating frequency and output voltage (travel) depend on operating conditions such as thermal coupling (single- or double-ended, with or without air cooling) length-to-diameter ratio and, of course, on the driving waveform.

The maximum possible frequency for a particular system should be determined after the system is set up with the defined operating conditions by slowly running the system up to the point where the controller performs a thermal shutdown. It is important to take proper account of the temperature sensor time constant, the mechanical characteristics of the system, and the amplifier parameters.

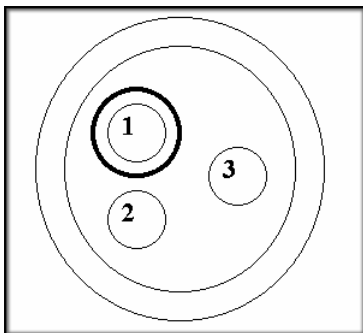

Figure 1: Temperature sensor connector of the E-618.10, view from solder side

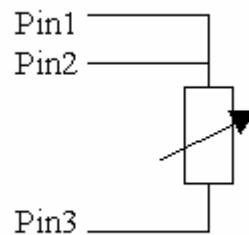

Figure 2: Temperature sensor diagram

Pin assignment:

- Pin 1: Temp_SA
- Pin 2: Temp_S
- Pin 3: GND/PE
- Housing: Shield/GND/PE

2.8 Control Signal Connection

2.8.1 Analog Operation

All E-618 versions can be operated by an analog control signal. The output voltage (if in open-loop operation) or the actuator position (closed-loop operation) is directly proportional to this analog control signal. The analog control signal consists of two components:

Analog control signal = CONTROL INPUT + DC OFFSET

where

CONTROL INPUT is the voltage connected to the corresponding BNC socket on the front panel

DC OFFSET is the DC offset voltage set via the corresponding potentiometer on the front panel (0 to 10 V)

-2 to 12 V is the recommended range for the analog control signal, resulting in -20 to 120 V piezo output voltage. A range of -3 to 13 V is possible and will result in -30 to 130 V output voltage, but working with increased output voltage will decrease actuator lifetime. See "Lifetime of PICMA® Actuators" on p. 29 for details.

The signal applied to the CONTROL INPUT BNC socket can be generated using a DAC-board in a PC. PI offers a LabVIEW driver set which can be used with certain D/A boards. This driver set is compatible with the PI General Command Set (GCS) LabVIEW driver set available for all newer controllers from PI. In addition, PI's patented HyperBit technology for providing position resolution higher than that of the D/A board is included in the E-500.ACD driver set (see "Model Survey and Upgrades" p. 7).

2.8.2 Remote Control via Computer Interface

E-618.1G models equipped with an E-517 computer interface and display module can be controlled from a host computer via the TCP/IP, USB, RS-232 or IEEE 488 PC interface. See the E-517 User Manual for details.

2.9 Modes of Operation

2.9.1 Open-Loop Operation

All E-618 versions can be operated in open-loop mode. Open-loop operation means that any control input provided by the user determines the output voltage directly.

2.9.2 Closed-Loop Operation

Closed-loop operation requires a position sensor and a servo-control module, e.g. E-509. Only E-618.1G models can be upgraded with E-509 modules.

Closed-loop operation means that the user commands the piezo excursion. The output voltage required to reach this target position is calculated internally by the servo-loop, based on the given target and the feedback of the position sensors (see E-509 User Manual PZ77E).

Note: In closed-loop operation up to 10% of the amplifier output range may be required for compensating nonlinearity and drift.

2.10 First Steps

The following instructions refer to analog operation (p. 17) of the system. If your E-618 is equipped with an E-517 computer interface and display module and you want to control the system via the computer interface, perform only steps 1 and 2 of the instructions below and then operate the system as described in the E-517 User Manual.

- 1 Make sure the E-618 is connected to line voltage but powered down. See "Line Voltage Connection" (p. 14) for details.
- 2 Connect the piezo actuator to the "PZT" socket of the E-618.
- 3 If the piezo actuator is equipped with a PT1000 temperature sensor, connect this sensor to the "TEMP SENSOR" socket of the E-618. Otherwise connect the included dummy plug (order No. 000016103) to this socket.
- 4 For closed-loop systems only (E-618.1G with E-509 module; see also the E-509 User Manual):
 - 4.1 Connect the sensor cable to the corresponding socket.

- 4.2 If you are using the sensor monitor signal, connect your appropriate electronics to the SENSOR MONITOR socket.
- 4.3 Set "SERVO" toggle switch on the servo module "OFF".
- 5 Turn the DC-OFFSET potentiometer fully counterclockwise (CCW).
- 6 Make sure that the voltage at "CONTROL INPUT" is set to 0 V.
- 7 Turn on the E-618. The green "POWER" LED will light up.
- 8 Command the first motion of the piezo actuator by turning the offset potentiometer fully clockwise (CW) to run the actuator over the nominal travel range, then turn the potentiometer back fully CCW.

If an E-517 interface and display module is installed, watch the voltage and, if an E-509 servo module is present, the position on the display to check whether the system is operating properly. Make sure that the full voltage swing is attained

If an E-509 servo module is installed, the SENSOR MONITOR signal will show a voltage from about 0 up to 10 V and then 0 V again, proportional to the piezo extension.

Example: A piezo actuator with a nominal travel of 100 μm shows a sensor monitor signal of 1.5 V at 15 μm . For an actuator with 30 μm nominal travel, 1.5 V at sensor monitor would correspond to 4.5 μm (15% of 30 μm)

- 9 If desired, connect a signal source to the "CONTROL INPUT" BNC socket. You can adjust the resulting analog control signal with the DC-OFFSET potentiometer. See "Control Signal Connection" (p. 17) for details.

E-618.1G models equipped with E-509 servo-control modules:

If you switch to closed-loop operation (servo ON), the yellow "OFL" overflow LED on the E-509 module may light up. In this case, a zero-point adjustment is necessary. Follow the instructions for zero-point adjustment given below. To avoid an overflow of the amplifier in open-loop operation, do not exceed the allowable control input range (-3 to +13 V).

2.11 Zero-Point Adjustment in Closed-Loop Operation with E-509

Zero-point adjustment on the E-509 sensor and servo-control module has the following goals:

- Making the full travel range available: If the electrical zero point is adjusted properly, the full output voltage range of the amplifier can be used in closed-loop operation. This prevents overflow conditions from occurring.
- Preserving the piezo actuators in the mechanics: The point of zero sensor readout should correspond to zero or a (small) negative output voltage. This technique can reduce the average applied voltage without loss of displacement and thereby increase piezo lifetime.

There might be some small deviation of the electrical zero-point caused by thermal drift or changes in mechanical loading. Let the system warm up for several minutes before setting the zero point. See also the E-509 User Manual, PZ77E.

If an E-517 interface and display module is present in the system, zero-point adjustment can be performed without additional equipment; see the E-517 user manual for further information. Otherwise a precision voltmeter is required for zero-point adjustment.

How to perform zero-point adjustment in analog open-loop operation:

- 1 Make sure the piezo actuator is mounted in the same way and with the same load as during normal operation in the application.
- 2 Make sure that the analog signal on CONTROL INPUT is 0 V and turn the DC-OFFSET potentiometer fully CCW.
- 3 Connect a precision voltmeter to the SENSOR MONITOR socket on the E-509 front panel.
- 4 Power up the system.
- 5 Set the SERVO toggle switch on the E-509 front panel to OFF. If an E-517 interface and display module is present in the system, make sure that servo is not set on with the SVO command.
- 6 Turn the DC-OFFSET potentiometer fully clockwise (10 V) and then back fully counterclockwise (0 V) to exercise the mechanics.
- 7 Adjust the ZERO potentiometer on the E-509 until a sensor-monitor signal of +1 V is measured by the precision voltmeter on the SENSOR MONITOR socket.

After successful zero-point adjustment, the “OFL” overflow LED on the E-509 module should no longer glow in closed-loop operation. Permanent glow of this LED in spite of zero-point adjustment may indicate hardware failure. To avoid an overflow of the amplifier in open-loop operation, do not exceed the allowable control input range (-3 to +13 V).

2.12 Protection Against Overheating

To protect the system against overheating, the piezo voltage output on the “PZT” socket is deactivated automatically in the following cases:

- A PT1000 temperature sensor connected to the E-618 detects a temperature of 150 °C on the mechanics. In this case, the red “TEMP OFL” LED on the front panel lights up.
- The internal temperature sensor of the E-618 detects a temperature of 85 °C at the electronics. In this case, the red “TEMP OFL” LED on the front panel does not light up.

If the piezo voltage output has been deactivated, the piezo actuator will no longer move. Proceed as follows:

1. Turn off the E-618 for a cooling phase.
2. Wait until the temperature has dropped on the mechanics and/or inside the electronics.
3. Power up the E-618 again.

Permanent deactivation of the piezo output voltage due to overheating may indicate hardware failure.

3 Maintenance

WARNING

Before changing the AC fuses or cleaning the E-618, switch the device off and disconnect it from the line voltage.



3.1 AC Power and Line Power Fuses

Unless otherwise requested, the unit will be set up for the power predominant in your country. New line-power fuses are required when changing the supply voltage.

CAUTION

Both fuses are active and have to be checked if there is a fault.

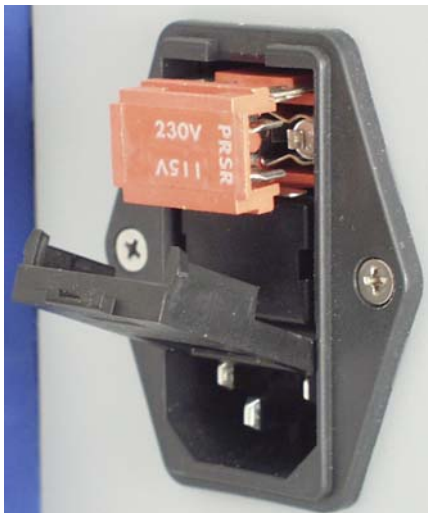

Figure 3: Position of the line fuses and fuse carrier, only one of two fuses visible



Figure 4: Fuse carrier

To access the line fuses, proceed as follows:

- 1 Switch off the E-618 and remove the line cord.
- 2 Wait a minute to be sure that any residual voltage has dissipated.
- 3 Pry open the door that covers the fuse carrier and pry out the fuse carrier (see figures above).
- 4 Be sure to replace both fuses with fuses of the type appropriate for the new voltage:

Single-channel systems: E-618.10G, E-618.1G, custom models with one E-618.10 module:

220 VAC to 240 VAC: 2 x IEC T2AH 250 V (slow blow)

100 VAC to 120 VAC: 2 x IEC T4AH 250 V (slow blow)

Two-channel systems: E-618.20G, custom models with two E-618.10 modules:

220 VAC to 240 VAC: 2 x IEC T4AH 250 V (slow blow)

100 VAC to 120 VAC: 2 x IEC T8AH 250 V (slow blow)

IEC fuses are cited: other fuse standards may require higher nominal current rating.

- 5 Rotate the fuse carrier so that the valid voltage setting (115 V or 230 V) will show through the window when the door is closed.
- 6 Reinstall the carrier and close the door.

3.2 Cleaning

The outside surface of the chassis can be cleaned using mild detergents or disinfectant solutions. Organic solvents must not be used.

4 Troubleshooting

4.1 Mechanics Does not Move

- Check the connecting cables.
- Check the analog control signal (CONTROL INPUT and DC-OFFSET setting). See p. 17 for more information.
- The piezo voltage output (PZT socket) may be deactivated due to overheating of mechanics and/or electronics. See p. 21 for more information.

4.2 The TEMP OFL LED Lights

- The connected temperature sensor is reporting 150 °C and the piezo voltage output has thus been shut off. Turn off the E-618. Wait until the temperature at the mechanics has dropped before powering the E-618 up again.

4.3 Customer Service

Still having problems? Call your local distributor or write to info@pi.ws; please have the following information about your system ready:

- Product codes and serial numbers of all products in the system
- Current firmware version of the controller
- Software version of drivers and / or host software
- Operating system on host PC

5 Technical Data

5.1 Specifications

	E-618.10
Function	Power amplifier module for PICMA® multilayer piezo actuators
Amplifier	
Input voltage	-2 to +12 V
Output voltage*	-30 to 130 V
Peak output power	> 3200 W (< 0.3 ms)
Average output power	100 W (> 0.3 ms)
Peak current	> 20 A (< 0.3 ms)
Average current	0.8 A (> 0.3 ms)
Current limitation	Short-circuit-proof
Voltage gain	10 ±0.1
Ripple, noise, 0 to 100 kHz	200mVpp/ 24mVrms (no load), 2mVrms (1µF)
Input impedance	100 kΩ
Interfaces and operation	
Piezo connector	LEMO EGG.1B.302.CLL, with security cover
Control input	BNC
Temperature sensor (piezo actuator)	PT 1000; LEMO socket; deactivation of the piezo voltage output at 150 °C actuator temperature
Display	Power, Temp Overflow LEDs
DC Offset	10-turn pot., adds 0 to +10 V to Control In

Miscellaneous	
Operating temperature range	+5°C to +50°C (output 10% derated over 40 °C)
Dimensions	215 x 123 x 185 mm insert for 42HP/3U 19" rackmount chassis
Mass	2.65 kg
Operating voltage	100 to 120 or 220 to 240 VAC, selectable
Max. power consumption	15 VA (no load) 160 VA (max. load)

*Deactivation of the piezo voltage output at 85 °C internal temperature (overtemp protection for electronics) or if 150 °C are measured by the temperature sensor at the piezo actuator.

5.2 Frequency Response Diagram

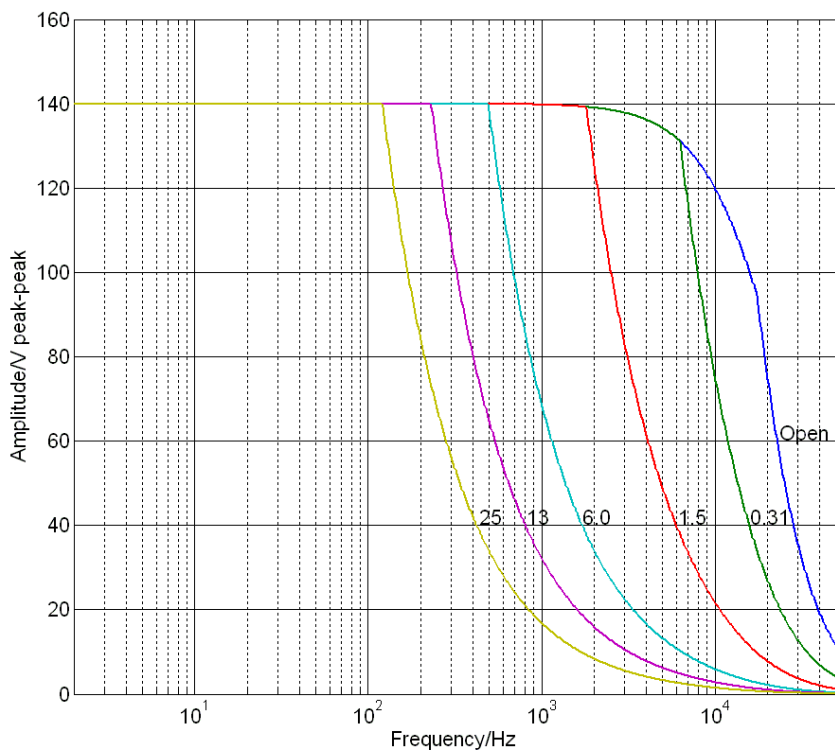

Figure 5: E-618.10 operating limits with various piezo loads (open-loop), capacitance is measured in μF

5.3 Block Diagram

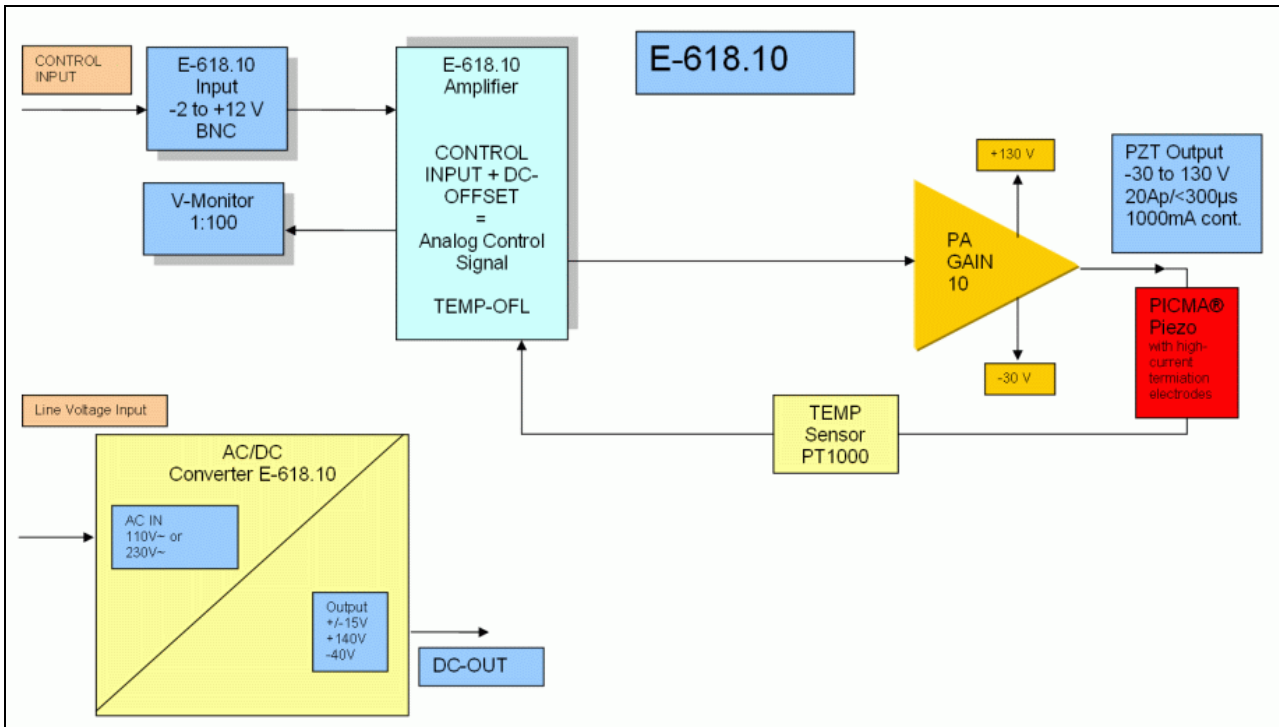

Figure 6: E-618.10 block diagram

5.4 Signal Path with Servo-Controller and PC-Interface Modules

The block diagram below shows the signal path for the E-618.1G model upgraded with an E-509 servo-control module and an E-517 interface and display module.

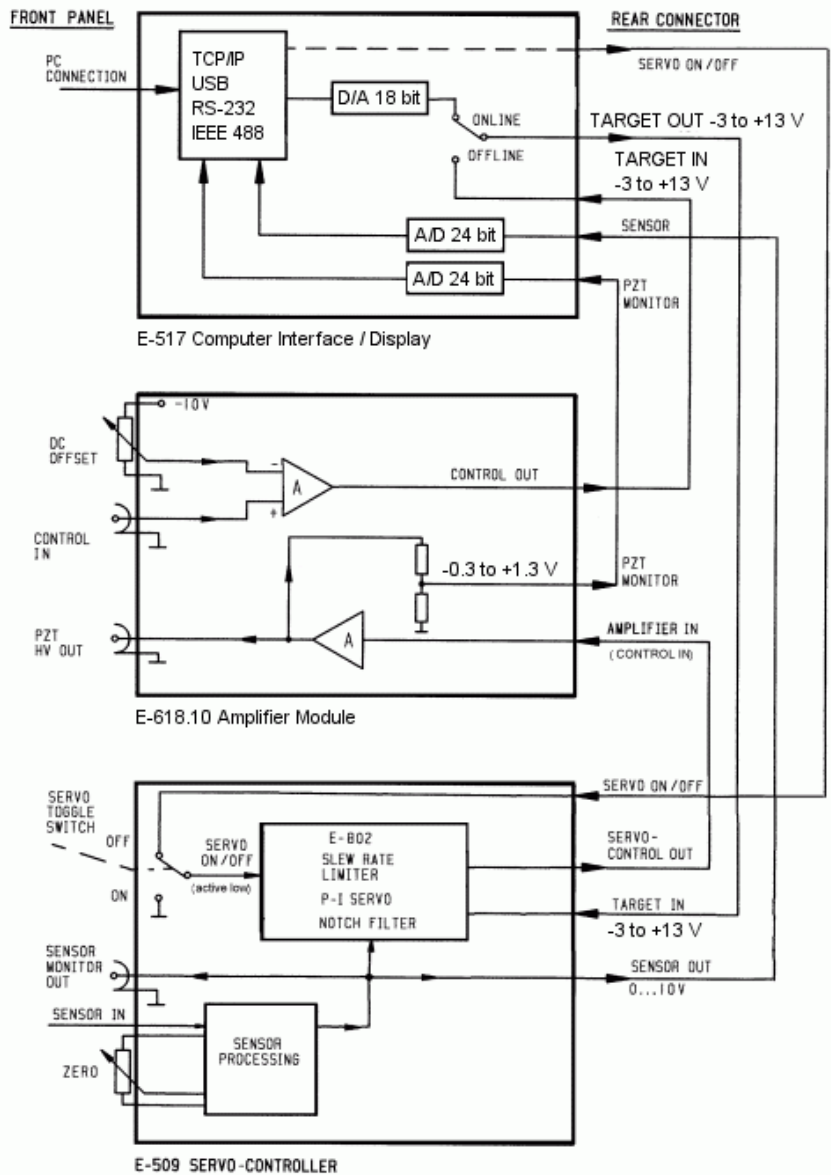

Figure 7: E-618.1G: Interconnections between E-517 Interface, power amplifier (E-618.10) and E-509 Servo-Controller

6 Appendix

6.1 Lifetime of PICMA® Actuators

The following factors can have an impact on the actuator lifetime and must be considered:

- Applied voltage
- Temperature
- Relative humidity

The effect of each individual factor on the lifetime can be read off the diagrams shown below. The lifetime calculated in hours simply results as the product of all three values read off the diagrams.

The impact of the applied voltage is particularly important. With decreasing voltage the lifetime increases exponentially. This must always be taken into consideration in an application. The recommended maximum range of the control input voltage for E-618 therefore is -2 to 12 V, resulting in a piezo voltage range of -20 to 120 V. A control input range of -3 to 13 V is possible (results in -30 to 130 V piezo voltage), but will reduce the actuator lifetime accordingly.

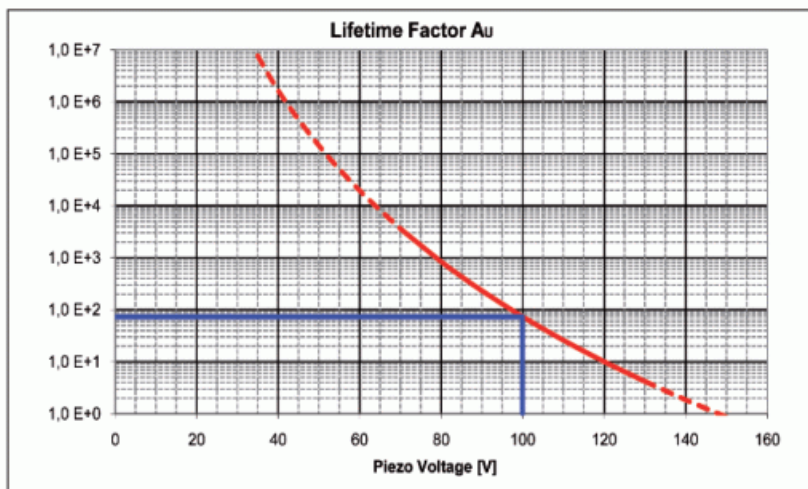

Fig. 1: Interdependency between the mean MTTF of a PICMA® actuator and the value of the voltage applied

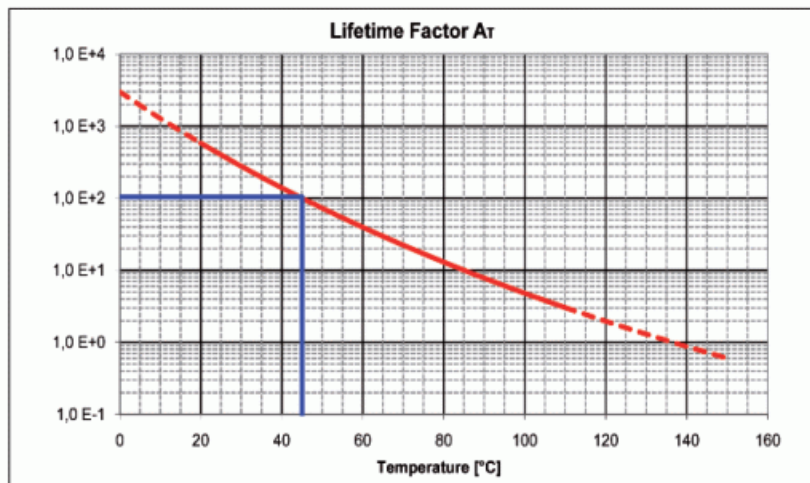

Fig. 2: Interdependency between the mean MTTF of a PICMA® actuator and the ambient temperature

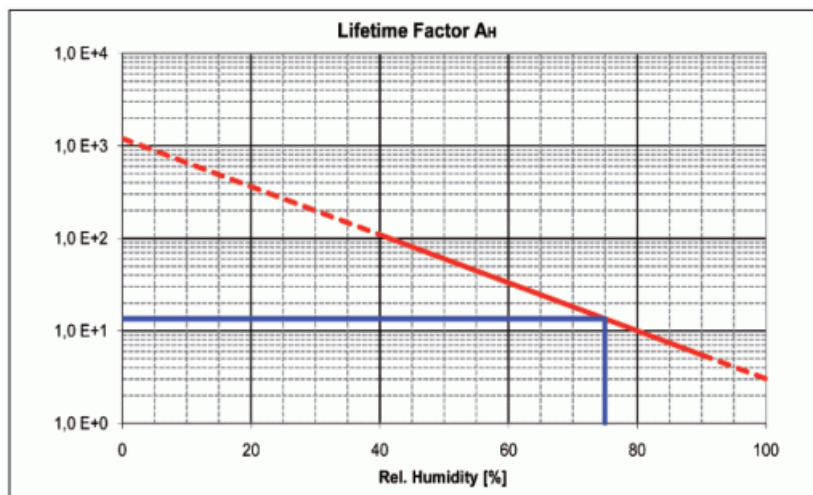

Fig. 3: Interdependency between the mean MTTF of a PICMA® actuator and the relative humidity

Example

The simple formula $MTTF = A_U * A_T * A_F$ provides a quick estimate of the reliability in hours.

For example, the values for 75% RH ($A_F=14$), 100 VDC ($A_U=75$) and 45 °C ($A_T=100$) result in an approximate MTTF of 105,000 h, i.e. more than 11 years (see markings on the diagrams).

Read the “Tutorial: Piezoelectrics in Positioning” in the PI Catalog for detailed information.

6.2 Power Bandwidth

The maximum frequency for sinusoidal operation of the E-618 depends on the actuator capacitance and on the piezo output voltage. It is given by the following equation:

$$f_{\max} = \frac{P}{C * U_{\max} * U_{p-p}}$$

f_{\max} = maximum operating frequency [Hz]

P = average power [W]; 100 W with E-618.10 amplifier modules

C = piezo actuator capacitance.
Note that the actuator capacitance values given in the technical data tables are small-signal values. For large signal conditions (actuator deflection is at least 10% of the travel range), multiply the small-signal capacitance value by 2.

U_{\max} = nominal voltage of the amplifier [V]; 180 V with E-618.10

U_{p-p} = peak-to-peak drive voltage [V], i.e. the piezo output voltage (peak-to-peak)

