



# **DDS100(/M) Direct Drive Translation Stage**

## **User Guide**



Original Instructions

# Contents

<b>Chaper 1</b>	<b>Overview</b>	<b>1</b>
	<b>1.1 Introduction</b>	<b>1</b>
<b>Chaper 2</b>	<b>Safety</b>	<b>2</b>
	<b>2.1 Safety Information</b>	<b>2</b>
	<b>2.2 General Warnings</b>	<b>3</b>
<b>Chaper 3</b>	<b>Installation</b>	<b>4</b>
	<b>3.1 Unpacking</b>	<b>4</b>
	<b>3.2 Mounting</b>	<b>4</b>
	3.2.1 Vertical Mounting	4
	3.2.2 General	4
	3.2.3 Mounting the Stage to the Work Surface	5
	3.2.4 Mounting In Multi-Axis Configurations	6
	<b>3.3 Electrical Connections</b>	<b>7</b>
<b>Chaper 4</b>	<b>Operation</b>	<b>8</b>
	<b>4.1 General</b>	<b>8</b>
	<b>4.2 Using the Kinesis software</b>	<b>9</b>
	<b>4.3 Using the APT Software</b>	<b>12</b>
	<b>4.4 Position Error Messages</b>	<b>15</b>
	<b>4.5 Transportation</b>	<b>15</b>
<b>Chaper 5</b>	<b>Maintenance</b>	<b>16</b>
	<b>5.1 General</b>	<b>16</b>
<b>Chaper 6</b>	<b>Specifications</b>	<b>17</b>
	<b>6.1 Stage Specifications</b>	<b>17</b>
<b>Chaper 7</b>	<b>Regulatory</b>	<b>19</b>
	<b>7.1 Declarations Of Conformity</b>	<b>19</b>
	7.1.1 For Customers in Europe	19
	7.1.2 For Customers In The USA	19
	<b>7.2 CE Certification</b>	<b>20</b>
<b>Chaper 8</b>	<b>Thorlabs Worldwide Contacts</b>	<b>22</b>

---

# Chapter 1 Overview

## 1.1 Introduction

The Thorlabs' DDS100 low-profile, direct-drive stage provides 100 mm of travel with 500 nm resolution and a maximum speed of 500 mm/s. The stage is ideal for applications that require high speeds and high positioning accuracy, including automated alignment, surface inspection, mapping, and probing.

An innovative low-profile design with integrated, brushless linear motors eliminates the external housings that create mechanical clash points and impede access to the moving platform. The direct-drive technology removes the need for a lead screw, eliminating backlash. A precision-grooved linear bearing provides superior rigidity and linearity with excellent on-axis accuracy. This backlash-free operation coupled with high-resolution, closed-loop optical feedback ensures a minimal bidirectional repeatability of 1.5  $\mu\text{m}$ . Along with the Thorlabs KBD101 controller and the Thorlabs software interface, it forms a truly plug and play system.

Characterized by high-speed translation and high-positional accuracy, the DDS100 stage is well-suited for surface mapping and characterization applications where there is a need to move a camera or probe at constant velocity while simultaneously capturing data.



Fig. 1.1 DDS100 Direct Drive Translation Stages in XY Configuration

## Chapter 2 Safety

### 2.1 Safety Information

For the continuing safety of the operators of this equipment, and the protection of the equipment itself, the operator should take note of the **Warnings, Cautions** and **Notes** throughout this handbook and, where visible, on the product itself.

The following safety symbols may be used throughout the handbook and on the equipment itself.



#### **Warning: Risk of Electrical Shock**

Given when there is a risk of injury from electrical shock.



#### **Warning**

Given when there is a risk of injury to users.



#### **Caution**

Given when there is a risk of damage to the product.

#### **Note**

Clarification of an instruction or additional information.

## 2.2 General Warnings



### Warning

If this equipment is used in a manner not specified by the manufacturer, the protection provided by the equipment may be impaired. In particular, excessive moisture may impair operation.

Spillage of fluid, such as sample solutions, should be avoided. If spillage does occur, clean up immediately using absorbant tissue. Do not allow spilled fluid to enter the internal mechanism.

When bolting the stage to the work surface, high tightening torque of the attachment bolts can result in an increased resistive force on the moving platform. This in turn can lead to degraded performance and may require the PID parameters to be adjusted. As a general guide, 70 N·cm is a recommended nominal torque when tightening the attachment bolts.

The equipment is for indoor use only.

When running custom move sequences, or under fault conditions, the stage may move unexpectedly. Operators should take care when working inside the moving envelope of the stage.

## Chapter 3 Installation

### 3.1 Unpacking

**Note**

Retain the packing in which the unit was shipped, for use in future transportation.



**Caution**

Once removed from its packaging, the stage can be easily damaged by mishandling. The unit should only be handled by its base, not by any attachments to the moving platform.

### 3.2 Mounting

#### 3.2.1 Vertical Mounting



**Warning**

The stage is not suitable for mounting in a vertical (Z-axis) configuration.

#### 3.2.2 General



**Caution**

The straightness of motion of the stage could be affected if the mounting surface is not flat. Care should be taken when bolting the stage to the worksurface, to ensure that the base plate does not warp. Shims should be fitted as necessary - see Section 3.2. for more details.

When bolting the stage to the work surface, high tightening torque of the attachment bolts can result in an increased resistive force on the moving platform. This in turn can lead to degraded performance and may require the PID parameters to be adjusted.

As a general guide, 70 N·cm is a recommended nominal torque when tightening the attachment bolts.

High drag forces can adversely affect phase initialization, homing, positioning accuracy and general reliability. Take care to minimize drag caused by attachments to the moving platform (cables, tubing, electrical wiring), especially when the stage is changing direction.

When mounting the stage close to other equipment, ensure that the travel of the moving platform is not obstructed. If equipment mounted on the moving platform is driven against a solid object, damage to the internal mechanism could occur. The range of travel is 100 mm (3.94").

### 3.2.3 Mounting the Stage to the Work Surface

The DDS100 stage is mounted to the working surface by two M6 x 25mm (1/4-20 x 1") screws. The mounting holes are accessed from the top of the stage - see Fig. 3.1.

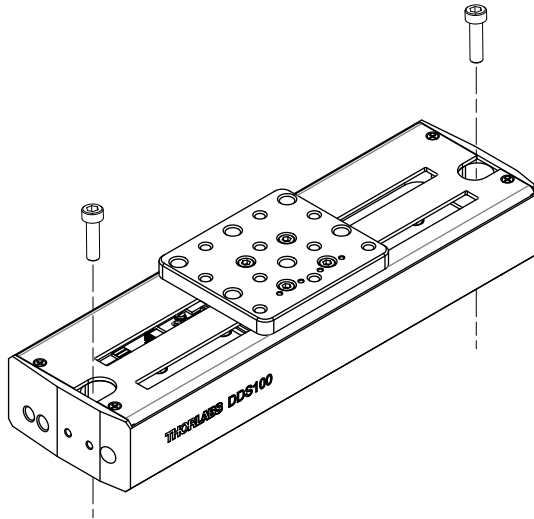

**Fig. 3.1 Mounting**



#### **Caution**

The performance of the stage could be affected if the mounting surface is not flat. Care should be taken when bolting the stage to the worksurface, to ensure that the base plate does not warp, which could cause stiffness to be experienced in the bearing rails. Shims should be fitted as necessary.

After mounting the stage to the work surface, if any increased resistance is experienced when moving the top platform, the likely cause is over tightening/torquing of the mounting bolts. As a general guide, 70 N·cm is a recommended nominal torque when tightening the attachment bolts.

Please contact tech support for more information.

### 3.2.4 Mounting In Multi-Axis Configurations

For dual-axis applications, two DDS100 stages can be bolted together in an XY configuration by using the DDSMP1 attachment plate.

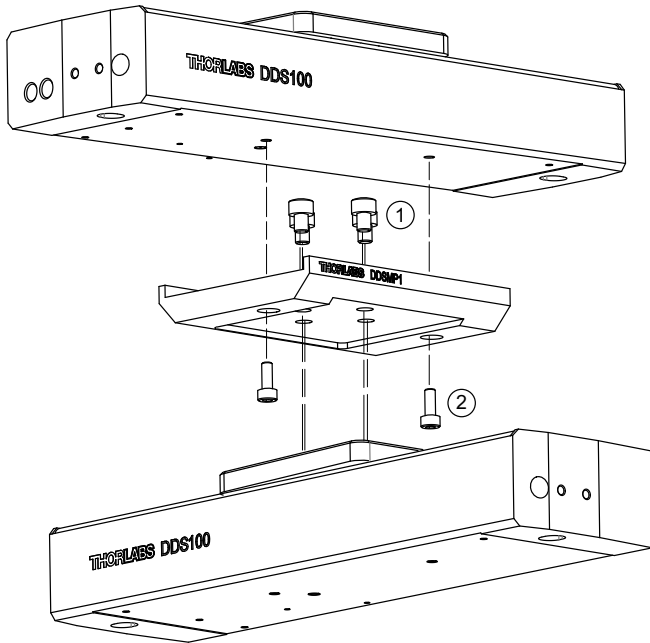

Fig. 3.2 Typical XY Configuration

Regarding Fig. 3.2 above:



#### Caution

During item (1), use the bolts supplied. If these are not available, do not use bolts longer than 3/32" (5 mm) as longer bolts could damage the internal mechanism.

- 1) Using the four 8-32 UNC (M4) bolts supplied, fit the DDSMP1 plate to the lower stage.



#### Caution

During item (2), use the bolts supplied. If these are not available, do not use bolts longer than 8 mm as longer bolts could damage the internal mechanism.

- 2) Using the two M3 bolts supplied, fit the upper stage to the adapter plate.



#### Caution

When stages are mounted in an XY configuration, the accelerations stated in Table 4.2 may require adjustment - see Section 4.1.



### 3.3 Electrical Connections

The stage must be driven by a Thorlabs KBD101 controller. Connect the motor flying lead to the MOTOR connector on the controller rear panel.

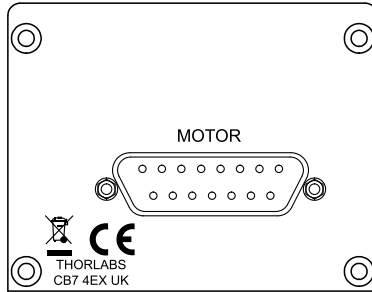

**Fig. 3.3 Electrical connections**

Pin out information for the connector on the motor lead is detailed below..

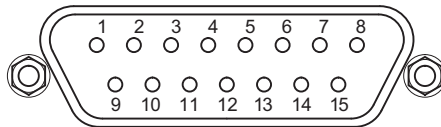

Pin	Description	Pin	Description
1	Quadrature A-	9	GND
2	Quadrature A+	10	Motor Phase C (Black)
3	Quadrature B+	11	Motor Phase A (Red)
4	Quadrature B-	12	Motor Phase B (White)
5	Encoder Index I-	13	+5 V
6	Encoder Index I+	14	GND
7	Negative Limit	15	Stage ID
8	Positive Limit		

**Fig. 3.4 MOTOR flying lead pin identification**

## Chapter 4 Operation

### 4.1 General



#### Caution

The DDS100 stage is designed to be driven by the Thorlabs KBD101 Brushless DC Motor K-Cube. For full compatibility, the controller should have Firmware version 1.0.1 or higher. The Firmware version is displayed on start up - see the associated controller manual for more information.

The stage is connected to the controller via a flying lead, terminated in a D-type connector.



#### Warning

The motor controller must be switched OFF before the stages are plugged in or unplugged. Failure to switch the controller off may result in damage to either the controller, the stage, or both.

For a complete tutorial on using the stage, see the manual supplied with the KBD101 controller. Basic steps in controlling the stage are as follows:

- 1) Make electrical connections as detailed in Section 3.3.
- 2) Manually position the moving platform to be around its central position.



#### Warning

3-phase brushless DC motors are commutated electronically, i.e. the controller drives the coils with a precisely controlled waveform, that depends on the position of the motor coil housing. On power up, the position of the coil housing is not known. The controller establishes this by energising the coils and measuring the resulting movement. This is why on power up, the stage (motor) may make a slight buzzing noise and move slightly. Phase initialisation can only take place if the motor can move unobstructed during this time. Before powering up the KBD101 controller at item (2), ensure that the stage movement is unobstructed.

- 3) Power up the KBD101 controller and wait until the Channel Enable LED starts flashing (~3s).
- 4) Press and hold the ENABLE button for ~3 seconds to initiate a home sequence. Alternatively, run the software and click the 'Home' button on each GUI panel. When homing is complete, the Channel Enable LED stops flashing.

**Note**

The need for homing comes from the fact that on power up the motor (stage) is at a random position, so the value of the position counter is meaningless. Homing involves moving the motor to a known reference marker and resetting the position counter to the associated absolute value. This reference marker can be one of the limit switches or can be provided by some other signal. The DDS series stages use an electronic reference marker and therefore the limit switches are not used for reference.

- 5) The stage can now be moved using the Pot, GUI panel, or by setting commands to move each axis by relative and absolute amounts – see the handbook supplied with the KBD101 controller, and the helpfile supplied with the software for more information
- 6) The stage is shipped already loaded with default parameter settings, which should give satisfactory performance in most cases. However, depending on the application, it may be necessary to adjust the PID loop parameter settings to fine tune the response - see the following pages for more information.

**4.2 Using the Kinesis software**

- 1) If it is not already running, start the Kinesis software - Start/Programs/Thorlabs/Kinesis/Kinesis

The software reads in the stage and controller information on boot up and the GUI panel shown below is displayed..

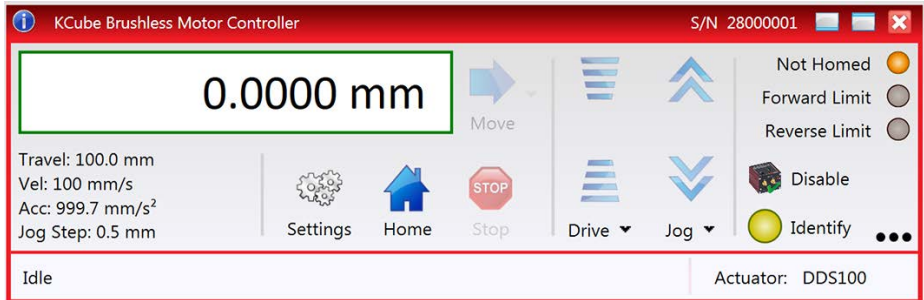

**Fig. 4.1 Kinesis GUI screen**

**Note**

The MOTOR DRIVE connectors for each channel/axis contain an EEPROM, which stores the factory default settings for the set up parameters. When the stage is connected, these settings are loaded into the controller on start up, and are tuned for loads up to the 250 g (0.55 lb) maximum, at speeds up to 500 mm/s.

However, depending on the load being driven and the speed/duty cycle of the particular application, it may be necessary to further optimize the Position PID loop settings. See Table 4.1 for suggested PID settings at a given load.

If problems are encountered (e.g. stability of the closed loop position control, lost motion or incomplete moves) the position loop PID parameters should be adjusted to tune the stage for the given application. Normally, only minor adjustment of the Proportional, Integral and Derivative parameters should be necessary, and some trial and error will be required before the ideal settings for a specific application are achieved. In cases where further adjustment of the control loop parameters is required, the following guidelines are provided in order to assist in the tuning process.

- 2) Click the Settings button on the GUI to display the Settings panel, then select the 'Advanced' tab.

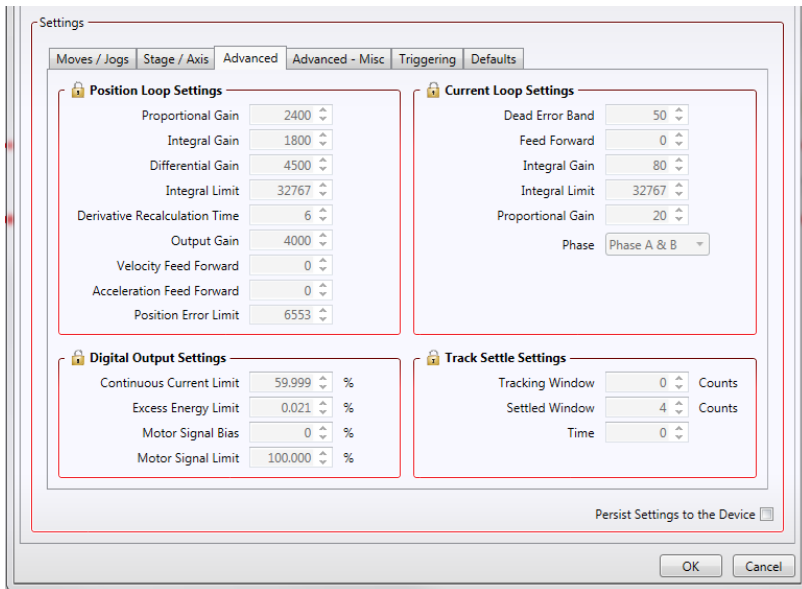

**Fig. 4.2 Advanced Control Loop Settings**

- 3) Create a Custom Settings Group (see the Kinesis helpfile for more information) and then adjust the acceleration and PID settings to fine tune the control loop for your application - see Table 4.1 and Table 4.2 for more information.

- 4) After the parameter changes have been performed, click the 'Persist Settings to Hardware' box, then click 'OK'. This will ensure that the same parameter settings will be loaded next time the unit is powered up - even in the absence of a PC.

Table 4.1 DDS100 Position Loop Parameter Adjustment Guidelines

Load Range (g)	Derivative	Derivative Time	Output Gain
0 to 250	4500	5	4000
250 to 500	5160	5	4660
500 to 750	5830	6	5330
750 to 900	6500	7	6000

Depending on the shape of the mass and the accelerations and velocities used the values quoted above may require adjustment to provide optimum performance.

Table 4.2 DDS100 Load vs Maximum acceleration recommendations

Load (g)	Approximate Max Acceleration (mm/s <sup>2</sup> )
0	5000
125	2400
250	1550
500	925
750	650
900	500

The values quoted above are the maximum values recommended to avoid over current errors. These values are a guideline only, and depending on the shape of the mass and the velocities used, these values may require further adjustment, particularly if the stages are mounted in an XY configuration.

#### Note

##### Position PID Settings Summary

Stage overshoots the intended position - reduce the integral term, and increase the derivative and proportional terms.

Stage fails to attain final position - increase the integral and proportional terms.

Motion is unstable - reduce the proportional and integral terms, increase the derivative term.

Stage sounds noisy - reduce the derivative term.

Please see the handbook supplied with the controller, for more information on changing these settings

### 4.3 Using the APT Software

- 1) If it is not already running, start the APTUser utility - Start/Programs/Thorlabs/APT User/APT User  
The APT server reads in the stage and controller information on boot up and the GUI panel shown below is displayed.



Fig. 4.3 APTUser GUI screen

#### Note

The MOTOR DRIVE connectors for each channel/axis contain an EEPROM, which stores the factory default settings for the set up parameters. When the stage is connected, these settings are loaded into the controller on start up, and are tuned for loads up to the 250 g (0.55 lb) maximum, at speeds up to 500 mm/s.

However, depending on the load being driven and the speed/duty cycle of the particular application, it may be necessary to further optimize the Position PID loop settings. See Table 4.1 for suggested PID settings at a given load.

If problems are encountered (e.g. stability of the closed loop position control, lost motion or incomplete moves) the position loop PID parameters should be adjusted to tune the stage for the given application. Normally, only minor adjustment of the Proportional, Integral and Derivative parameters should be necessary, and some trial and error will be required before the ideal settings for a specific application are achieved. In cases where further adjustment of the control loop parameters is required, the following guidelines are provided in order to assist in the tuning process.

- 2) Click the Settings button on the GUI to display the Settings panel, then select the 'Advanced' tab.

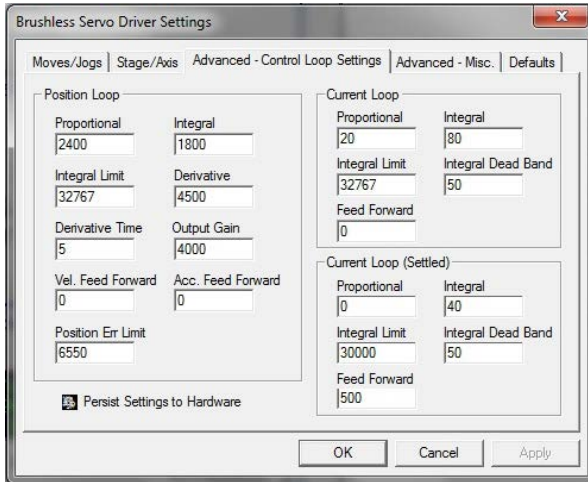

**Fig. 4.4 Advanced Control Loop Settings**

- 3) Adjust the acceleration and PID settings to fine tune the control loop for your application see Table 4.1 and Table 4.2 for more information.
- 4) After the parameter changes have been performed, click the 'Persist Settings to Hardware' box, then click 'OK'. This will ensure that the same parameter settings will be loaded next time the unit is powered up - even in the absence of a PC.

**Table 4.1 DDS100 Position Loop Parameter Adjustment Guidelines**

Load Range (g)	Derivative	Derivative Time	Output Gain
0 to 250	4500	5	4000
250 to 500	5160	5	4660
500 to 750	5830	6	5330
750 to 900	6500	7	6000

Depending on the shape of the mass and the accelerations and velocities used the values quoted above may require adjustment to provide optimum performance.

**Table 4.2 DDS100 Load vs Maximum acceleration recommendations**

Load (g)	Approximate Max Acceleration (mm/s <sup>2</sup> )
0	5000
125	2400
250	1550

Table 4.2 DDS100 Load vs Maximum acceleration recommendations

Load (g)	Approximate Max Acceleration (mm/s <sup>2</sup> )
500	925
750	650
900	500

The values quoted above are the maximum values recommended to avoid over current errors. These values are a guideline only, and depending on the shape of the mass and the velocities used, these values may require further adjustment, particularly if the stages are mounted in an XY configuration.

**Note**

Position PID Settings Summary

Stage overshoots the intended position - reduce the integral term, and increase the derivative and proportional terms.

Stage fails to attain final position - increase the integral and proportional terms.

Motion is unstable - reduce the proportional and integral terms, increase the derivative term.

Stage sounds noisy - reduce the derivative term.

Please see the handbook supplied with the controller, for more information on changing these settings



## 4.4 Position Error Messages



### Caution

The maximum velocity at which the encoder can operate is approximately 3000 mm/sec. Above this speed, encoder pulses may be lost and, as a result, the position readout becomes incorrect. This renders normal operation impossible because phase commutation of the motor is also based on the encoder reading.

When the stage is controlled by the KBD101 controller, the maximum velocity is limited to safe values. However, if the output is disabled (with the controller connected and monitoring the position) and the stage is moved manually at high speeds, it is possible to exceed this limit. If the KBD101 controller is subsequently used again to move the stage, the incorrect encoder reading will cause incorrect operation, often resulting in sudden uncontrolled moves. It is therefore important not to move the stage excessively quickly when it is moved manually.

The KBD101 controller has fault monitoring to detect the loss of encoder pulses. If this fault occurs, an error message will be generated and the controller must be powered down and re-started so that correct phasing and commutation can be established.

## 4.5 Transportation



### Caution

When packing the unit for shipping, use the original packing. If this is not available, use a strong box and surround the unit with at least 100 mm of shock absorbent material.

## **Chapter 5 Maintenance**

### **5.1 General**

Repetitive movement over long periods can result in build up of lubricant which can cause uneven motion. Periodically, the stage should be powered down and the top platform moved from one end of travel to the other several times to redistribute the bearing lubricant.

## Chapter 6 Specifications

### 6.1 Stage Specifications

Parameter	Value
Travel Range	100 mm (3.9")
Speed (Max) <sup>a</sup>	500 mm/s
Speed (Min) <sup>b</sup>	70 nm/s
Acceleration (Max)	5000 mm/s <sup>2</sup>
Acceleration (Max) at 0.9 kg Load	500 mm/s <sup>2</sup>
Resolution	500 nm
Bidirectional Repeatability	±1.5 µm
Backlash	N/A (No Leadscrew)
Min Incremental Movement	5.0 µm
Horizontal Load Capacity	0.9 kg (1.98 lbs)
Absolute On-Axis Accuracy	±6.5 µm
Straightness/Flatness	±5.0 µm
Pitch	±175 µrad
Yaw	±175 µrad
Continuous Motor Force <sup>c</sup>	0.8 N
Peak Motor Force (5 sec) <sup>d</sup>	2.0 N
Bearing Type	High Rigidity Recirculating Precision Linear Bearing
Limit Switches	Magnetic Sensor at Each End of Stage
Operating Temperature Range	5 to 40 °C (41 to 104 °F)
Motor Type	Brushless DC Linear Motor
Cable Length	1 m (3.3')
Dimensions	195.0 mm x 57.0 mm x 35.0 mm (7.68" x 2.24" x 1.38")
Weight (with cables)	0.72 kg (1.6 lbs)

#### Note

The default tuning parameters can be changed to optimise settling times for a specific load - see Section 4.1.

<sup>a</sup> The stage is designed for translation at high speeds, up to 500 mm/sec. When travelling at extremely low speeds (i.e. around 70 nm/sec) the discrete steps in the movement may be noticeable.

<sup>b</sup> Theoretical minimum.

<sup>c</sup> The continuous force the motor can deliver without exceeding temperature limits.

<sup>d</sup> The absolute maximum force the motor can deliver before going out of position error.



**Caution**

The maximum speed and acceleration values quoted can be safely achieved with the maximum load and a high duty cycle. However in this case, some heating of the stage may occur and dimensional stability of the stage may be affected. This could result in less than optimal repeatability and accuracy. For cases where repeatability and accuracy are critical it is recommended that the stage temperature is allowed to reach a steady state before measurements are taken.

Alternatively the load, acceleration and duty cycle should be reduced from the maximum values. Some trial and error in setting these values may be necessary before the ideal settings are attained.

## Chapter 7 Regulatory

### 7.1 Declarations Of Conformity

7.1.1 For Customers in Europe  
See Section 7.2.

#### 7.1.2 For Customers In The USA

This equipment has been tested and found to comply with the limits for a Class A digital device, pursuant to part 15 of the FCC rules. These limits are designed to provide reasonable protection against harmful interference when the equipment is operated in a commercial environment. This equipment generates, uses and can radiate radio frequency energy and, if not installed and used in accordance with the instruction manual, may cause harmful interference to radio communications. Operation of this equipment in a residential area is likely to cause harmful interference in which case the user will be required to correct the interference at his own expense. Changes or modifications not expressly approved by the company could void the user's authority to operate the equipment.

## 7.2 CE Certification



**THORLABS**  
www.thorlabs.com

**EU Declaration of Conformity**  
*in accordance with EN ISO 17050-1:2010*

We: Thorlabs Ltd.  
Of: 204 Lancaster Way Business Park, Ely, CB6 3NX, UK

*in accordance with the following Directive(s):*

2006/42/EC	Machinery Directive (MD)
2014/30/EU	Electromagnetic Compatibility (EMC) Directive
2011/65/EU	Restriction of Use of Certain Hazardous Substances (RoHS)

hereby declare that:  
Model: **DDS100, DDS100/M**

Equipment: **Compact 100 mm Travel Direct Drive Stage**

*is in conformity with the applicable requirements of the following documents:*

EN ISO 12100	Safety of Machinery. General Principles for Design. Risk Assessment and Risk Reduction	2010
Authorised to compile the technical file:	Thorlabs GmbH Münchner Weg1, 85232 Bergkirchen, Deutschland	
EN 61326-1	Electrical Equipment for Measurement, Control and Laboratory Use - EMC Requirements	2013

*and which, issued under the sole responsibility of Thorlabs, is in conformity with Directive 2011/65/EU of the European Parliament and of the Council of 8th June 2011 on the restriction of the use of certain hazardous substances in electrical and electronic equipment, for the reason stated below:*

does not contain substances in excess of the maximum concentration values tolerated by weight in homogenous materials as listed in Annex II of the Directive

*I hereby declare that the equipment named has been designed to comply with the relevant sections of the above referenced specifications, and complies with all applicable Essential Requirements of the Directives.*

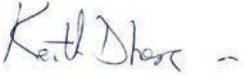
Signed:  On: 15 January 2021

Name: Keith Dhese  
Position: General Manager

EDC - DDS100, DDS100/M -2021-01-15



## Chapter 8 Thorlabs Worldwide Contacts

For technical support or sales inquiries, please visit us at [www.thorlabs.com/contact](http://www.thorlabs.com/contact) for our most up-to-date contact information.



### USA, Canada, and South America

Thorlabs, Inc.  
[sales@thorlabs.com](mailto:sales@thorlabs.com)  
[techsupport@thorlabs.com](mailto:techsupport@thorlabs.com)

### Europe

Thorlabs GmbH  
[europe@thorlabs.com](mailto:europe@thorlabs.com)

### France

Thorlabs SAS  
[sales.fr@thorlabs.com](mailto:sales.fr@thorlabs.com)

### Japan

Thorlabs Japan Inc.  
[sales@thorlabs.jp](mailto:sales@thorlabs.jp)

### UK and Ireland

Thorlabs Ltd.  
[sales@uk.thorlabs.com](mailto:sales@uk.thorlabs.com)  
[techsupport.uk@thorlabs.com](mailto:techsupport.uk@thorlabs.com)

### Scandinavia

Thorlabs Sweden AB  
[scandinavia@thorlabs.com](mailto:scandinavia@thorlabs.com)

### Brazil

Thorlabs Vendas de Fotônicos Ltda.  
[brasil@thorlabs.com](mailto:brasil@thorlabs.com)

### China

Thorlabs China  
[chinasales@thorlabs.com](mailto:chinasales@thorlabs.com)

Thorlabs verifies our compliance with the WEEE (Waste Electrical and Electronic Equipment) directive of the European Community and the corresponding national laws. Accordingly, all end users in the EC may return "end of life" Annex I category electrical and electronic equipment sold after August 13, 2005 to Thorlabs, without incurring disposal charges. Eligible units are marked with the crossed out "wheelie bin" logo (see right), were sold to and are currently owned by a company or institute within the EC, and are not disassembled or contaminated. Contact Thorlabs for more information. Waste treatment is your own responsibility. "End of life" units must be returned to Thorlabs or handed to a company specializing in waste recovery. Do not dispose of the unit in a litter bin or at a public waste disposal site.



**UNLEASHED**



**THORLABS**  
[www.thorlabs.com](http://www.thorlabs.com)

---