



# EoSens<sup>®</sup> 3CL

High-Speed CMOS Camera



## EoSens<sup>®</sup> 3CL

### Advantages at a Glance:

- Maximum photo sensitivity:  
1,200 ASA monochrome,  
1,000 ASA RGB
- Up to 150,000 fps at  
reduced resolution
- Full Camera Link<sup>®</sup> interface  
with 850 MB/second
- Monochrome or color  
with Bayer-filter
- Extended dynamic range  
up to 80 dB
- Small and compact design

## 3 Megapixel Resolution at 285 fps: Extremely Flexible in Resolution and Speed

### Lighting Becomes a Minor Matter

The EoSens<sup>®</sup> 3CL meets the requirements for most varied applications, because resolution and speed are variable adjustable. A resolution of 1,690 (H) x 1,710 (V) pixels ensures superb image quality with extremely sharp images. With the proven MIKROTRON high-speed technology the camera takes up to more than 150,000 frames per second.

## Dynamic Range Adjustment

The camera's Dynamic Range Adjustment feature allows to change the CMOS sensor's linear transfer characteristic into a non-linear one. Thus, the camera provides clear details even at extreme dark/light contrasts.

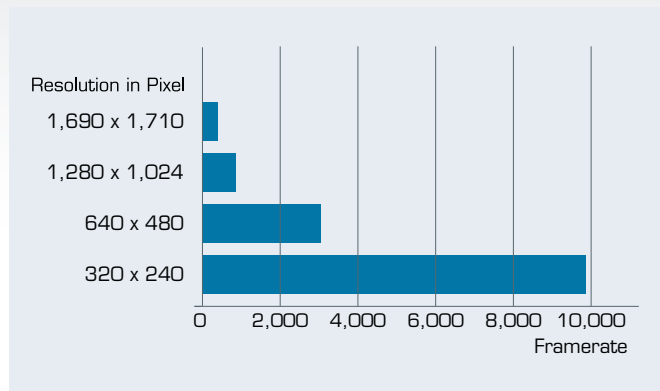

## “Freeze Frame” Full-Frame Shutter

The EoSens® 3CL features a “Freeze Frame” shutter that is able to process and store a complete frame while exposing the next image. At exposure times down to 1  $\mu$ s, this even enables the camera to capture fast moving objects at high definition in synchronous, free run and asynchronous triggered mode.

## Technical Data

(More detailed specifications are available on request)

EoSens® 3CL	
Resolution	3 Mpix
Interface	CameraLink® full
Max. Framerate (8 bit)	285
Sensor	CMOS global shutter
Sensor format	1"
Active Pixel	1,690 x 1,710
Pixel size	8 x 8 $\mu$ m
Max. No. of ROIs	1
Speed raise will reached by	lines and columns
ASA	1,200 / 1,000
Color depth	8 bit
Dynamic Range	80 dB
Shutter time (Steps)	2 $\mu$ s
Min. Shutter speed	1 $\mu$ s – 1 s
GPIO	STRB
Available mount option	C- and F-Mount
Camera size	63 x 63 x 47 mm (C-Mount)
Weight	300 g (C-Mount)
Power consumption	7 W
Camera body temperature	+5 ... 50 °C
Shock proof	70 g, 7 grms
Power supply	8 – 24 V DC

## Camera Body Dimensions

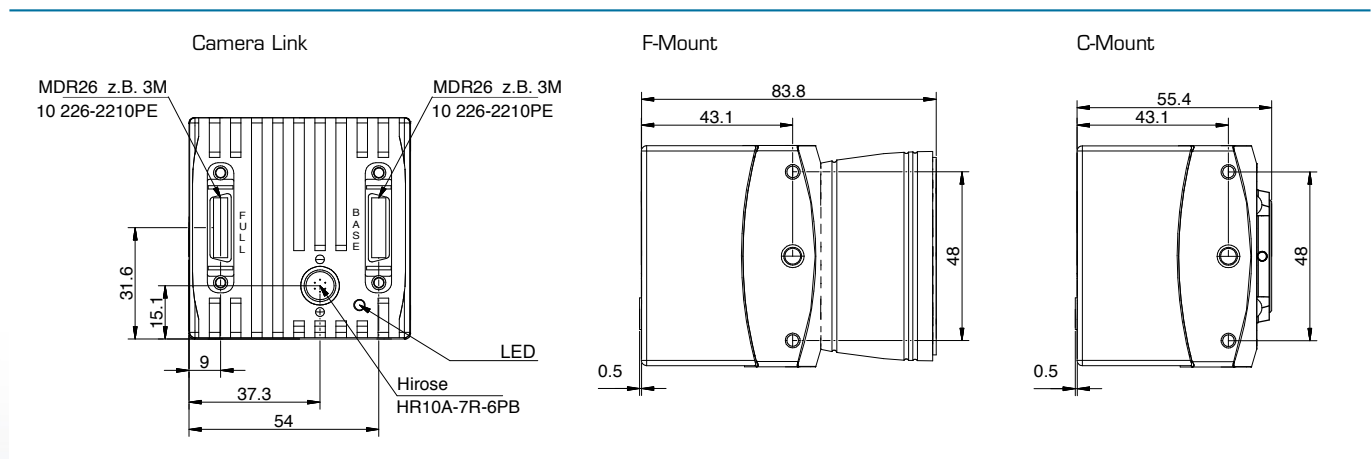

## MIKROTRON GmbH

MIKROTRON is a renowned manufacturer of small and robust high-speed cameras on the international industrial image processing market. Due to their outstanding performance characteristics the cameras are perfectly suited for usage in industrial and scientific applications, as well as in sports analysis, advertisements or documentaries.

### Germany

Landshuter Str. 20-22  
D-85716 Unterschleissheim  
Phone: +49(0)89-726342-00  
E-Mail: [info@mikrotron.de](mailto:info@mikrotron.de)  
Web: [www.mikrotron.de](http://www.mikrotron.de)

### North America

12172 Caddy Row, Ste. 100  
San Diego, CA 92128 - USA  
Phone: +1(0)858-521-0496  
E-Mail: [steve.ferrell@mikrotron.de](mailto:steve.ferrell@mikrotron.de)  
Web: [www.mikrotron.de/en](http://www.mikrotron.de/en)