



Goldeye

G-008

- Affordable GigE Vision SWIR camera
- Power over Ethernet
- Compact industrial design, no fan

Description

Goldeye G-008 - High-speed, low-cost InGaAS camera

The new Goldeye G-008 is the fastest 1/4-VGA resolution short wave infrared camera (SWIR) with GigE Vision interface. With frame rates up to 344 fps at full resolution, versatile application fields can be addressed and processes can be sped up strongly. Thanks to its very affordable price, many cost-sensitive applications, where the lower resolution is sufficient, can benefit from the camera's outstanding performance.

Save time and money to integrate the camera into your system: a small form factor and multiple mounting options let the camera fit easily into compact system designs. Additionally, its standardized GigE Vision interface including Power over Ethernet (PoE) and comprehensive I/O control options simplify the connection to your software solution and the synchronization with other system components. The integrated thermo-electric sensor cooling and several on-board image correction features contribute to the Goldeye's outstanding image quality.

Reveal more of the invisible with Goldeye SWIR cameras!

Benefits and Features

- Compact industrial design
- Up to 344 fps at full resolution
- GigE Vision interface with PoE+
- Comprehensive I/O control options
- Automated on-board image correction
- Stabilized sensor-cooling, no fan
- Extended operating temperature range

Options

- Available with C-Mount, F-Mount, M42 Mount

Specifications

Goldeye	G-008
Interface	IEEE 802.3 1000BASE-T, IEEE 802.3af (PoE)
Resolution	320 (H) × 256 (V)
Spectral range	900 nm to 1700 nm
Sensor	InGaAs FPA 320 x 256
Sensor type	InGaAs
Cell size	30 μm x 30 μm
Cooling temperature	+20 °C, +25 °C +35 °C, +50 °C, or user-configurable
Temporal dark noise	420 e ⁻ (Gain0), 170 e ⁻ (Gain1)
Dark current	280 ke ⁻ /s (@ +25 °C FPA temperature)
Saturation capacity	2.5 Me ⁻ (Gain0), 170 ke ⁻ (Gain1)
Dynamic range	75 dB (Gain0), 60 dB (Gain1)
Lens mount	M42-Mount, F-Mount, C-Mount
Max frame rate at full resolution	344 fps
ADC	14 bit
Image buffer (RAM)	256 Mbyte
Output	
Bit depth	8 - 14 bit
Mono modes	Mono8, Mono12, Mono12Packed, Mono14
General purpose inputs/outputs (GPIOs)	
TTL I/Os	LVTTL I/Os: 1 Input, 1 Output
Opto-isolated I/Os	1 Input, 2 Outputs
RS-232	115 000 Baud, 8N1 (adjustable)
Operating conditions/dimensions	
Operating temperature	-20 °C to +55 °C (Case)
Power requirements (DC)	10.8 V to 30.0 V or via PoE
Power consumption (@12 V)	10.8 W (@ 12 V DC), <12.95 W (@ PoE),
Mass	340 g (with C-Mount adapter)
Body dimensions (L × W × H in mm)	78 × 55 × 55
Regulations	CE (2004/108/EC), RoHS (2011/65/EU), WEEE (2012/19/EU), FCC Class B

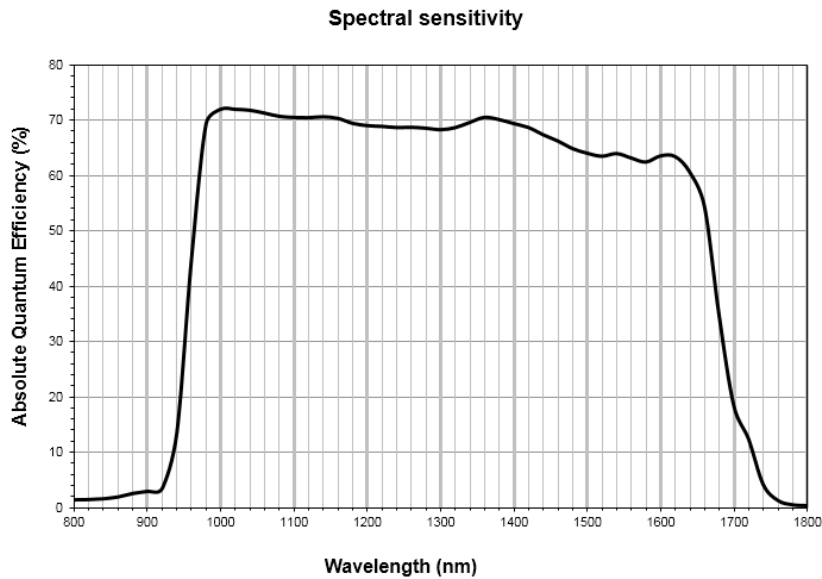

Features

IR-specific features (camera and sensor)

- Integrated correction data sets, compensation of sensor inhomogeneity and underlying structures (non-uniformity correction - NUC)
- Defect pixel correction
- Background correction
- Automated and manual sensor temperature management via TEC Features
- Temperature status LED

General features

- Exposure time control
- Gain (analog)
- I/O configuration and trigger control
- Stream hold (deferred image output)
- Storable user sets
- Firmware update in the field
- Region of interest (ROI) control, Look-up table (LUT) support, as well as various Auto-Features

Goldeye cameras are compatible with Allied Vision's Vimba SDK. Moreover, in combination with our AcquireControl software, extensive image analysis functions are available:

- Pseudo color LUT with several color profiles
- Auto contrast

- Auto brightness
- Analyze multiple regions (rectangular, circle) within the image
- Real-time statistics and histogram display

Technical drawing

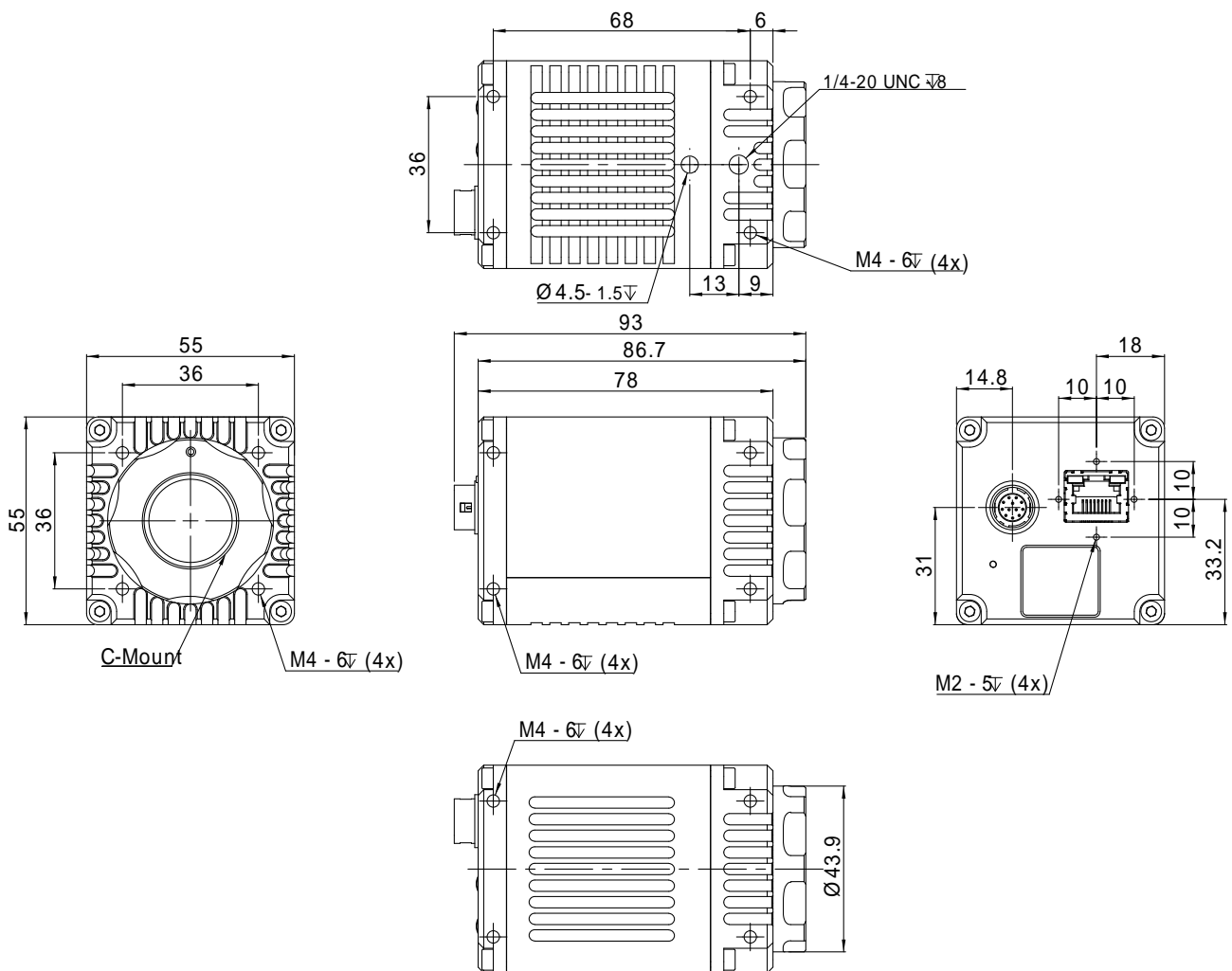

Applications

Goldeye cameras are very sensitive in the SWIR spectrum. They can be used in an extended operating temperature range. Thanks to TEC cooling and integrated image correction, Goldeye cameras achieve an outstanding image quality with little noise and a high dynamic range. They are well-suited for many typical SWIR applications in various industry branches:

- Semiconductor industry: solar cell and chip inspection
- Recycling industry: plastics sorting
- Medical imaging, sciences: hyperspectral imaging, microscopy, OCT
- Metal and glass industry: thermal imaging of hot objects (250 °C to 800 °C)
- Agriculture industry: airborne remote sensing
- Printing industry: banknote inspection
- Electronics industry: laser beam profiling
- Surveillance and security: vision enhancement (e.g., through fog or night vision)

White Paper

To learn more about typical application fields for SWIR cameras, download our White Paper:

[Seeing beyond the visible – short-wave infrared \(SWIR\) cameras offer new application fields in machine vision](#)